

Rainwater Tanks

Product Handbook
& Installation Guide

Made in Tasmania since 1998
Guaranteed quality
Free delivery to most areas
Large range of sizes and colours



ORION
AUSTRALIA

DIFFERENT. BETTER. GUARANTEED.

FREECALL
1800 752 784
WWW.ORIONAUSTRALIA.COM.AU

ORION AUSTRALIA TANK RANGE



Our tanks are manufactured from food grade UV stabilised polyethylene, which makes them tough, durable and able to withstand the harsh Australian sun. We only use material that is compliant with AS/NZS 4020 – suitable for potable water

They do not rust or corrode and are impact resistant

The single piece moulded construction ensures long term structural strength

Round Tanks

ROUND TANKS	CAPACITY (LITRES)	DIAMETER (MM)	INLET HEIGHT (MM)	OUTLETS	VALVE TYPE
RT00160	160	500	800	1 x ¾"	Bibcock
RT00500	500	800	1320	2 x ¾"	Bibcock
RT00550LP	550	1050	850	2 x ¾"	Bibcock
RT00950	950	960	1440	2 x ¾"	Bibcock
RT01100LP	1100	1350	1040	2 x 1"	Bibcock
RT02100LP	2100	1560	1270	2 x 1"	Bibcock
RT02400	2400	1350	1900	2 x 1"	Bibcock
RT04600	4600	1700	2250	2 x 1"	Brass Gate
RT06300LP	6300	2500	1380	2 x 1½"	Brass Gate
RT11250	11250	2560	2300	2 x 1½"	Brass Gate
RT22000	22000	3400	2700	2 x 1½"	Brass Gate

Available colours

Off White
Surf Mist™

Armour Grey
Windspray®

Metal Grey
Ironstone®

Mountain Blue
Deep Ocean®

Stormedge Blue
Blue Ridge™

Dusk
Evening Haze®

Popular!

Mist Green
Pale Eucalypt®

River Gum
Wilderness®

Heritage Green
Cottage Green®

Gull Grey
Shale Grey®

Desert Haze
Sandbank®

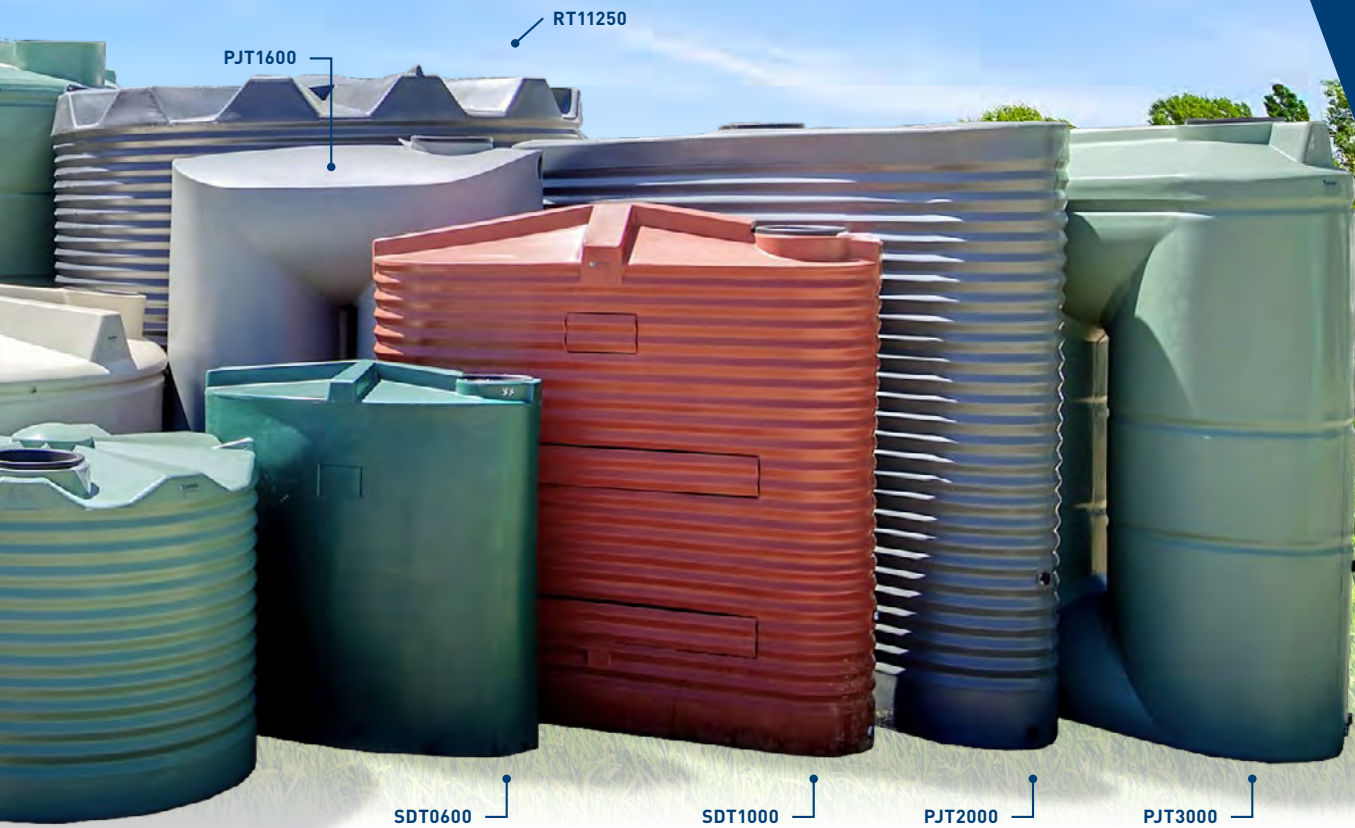

Installation is easy with a tap/valve and fit-up kit supplied with all rainwater tanks

Non-standard fit-up and additional outlet options available (upon request) to suit your particular requirements

Available in a wide range of colours and we can match many existing Colorbond® colours

Slimline Tanks

SLIMLINE TANKS	CAPACITY (LITRES)	LENGTH x WIDTH (MM)	INLET HEIGHT (MM)	OUTLETS	VALVE TYPE
SDT0600	600	1180 x 640	1270	2 x ¾"	Bibcock
SDT1000	1000	1800 x 500	1800	4 x 1"	Bibcock
PJT1600	1600	1530 x 730	2020	4 x 1"	Bibcock
PJT2000	2000	2400 x 600	2020	5 x 1"	Bibcock
PJT3000	3000	2500 x 800	2050	4 x 1"	Bibcock

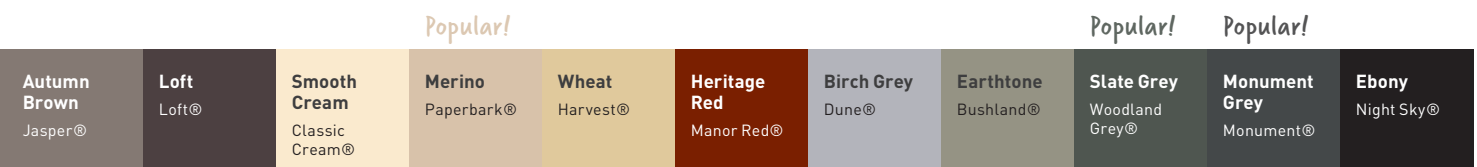

Due to variations in printing process, colours shown may not be a true representation of actual colour. Please confirm at time of order.

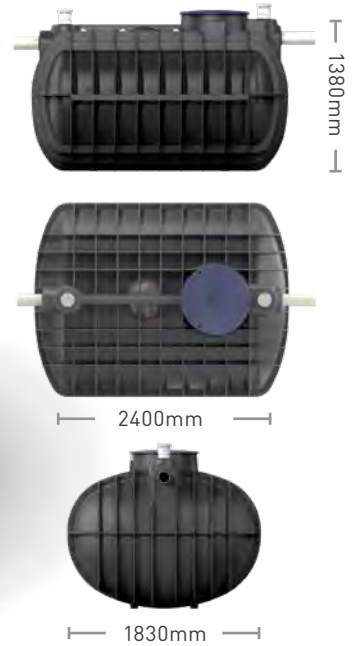
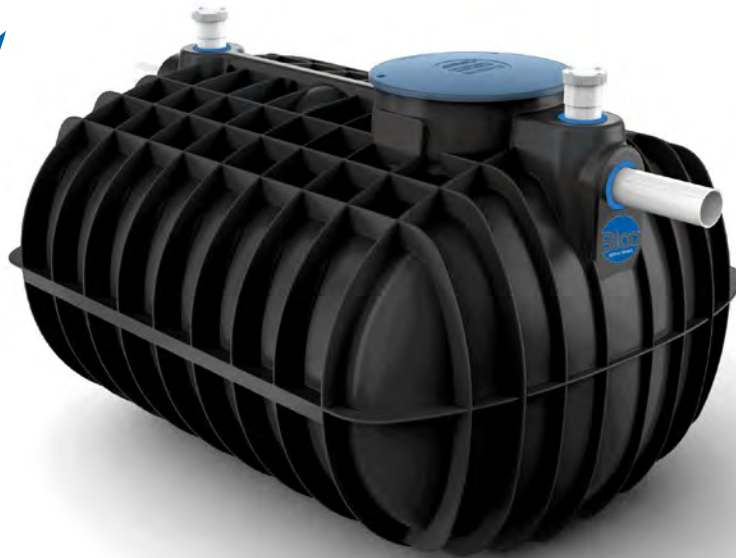

Bloo Septic Tanks

BLOO Septic Tanks are designed to minimise the amount of digging required prior to installation. By utilising a low profile design, the depth of excavation is minimised and the hole is easier to backfill after installation.

Fully preassembled before delivery, the BLOO Septic tanks are fully compliant with Australian Standards AS/NZS 1546.1:2008, and have quickly become the number one choice for many plumbers.

SEPTIC TANKS	TOTAL CAPACITY (LITRES)	WORKING CAPACITY	INLET HEIGHT (MM)	OUTLET INVERT HEIGHT	WEIGHT (KG)
UST3250	3700	2600	1870	2"	180



Bush Fire Ready

ORION AUSTRALIA supply galvanized tanks to satisfy the new BAL (Bushfire Attack Level) ratings to complement their already large range of water storage tanks. Available in galvanized finish.

ROUND TANKS	CAPACITY (LITRES)	DIAMETER (MM)	HEIGHT (MM)	OUTLETS
GRT10000-S	10,000	2600	1870	2"

DESCRIPTION: 10,000L galvanized fire tank, complete with 2" fitting and Tas Fire approved outlet.





Waterworks Home Package

INCLUDES

- > 2 x 22,000L Storage
- > 50 LPM Pump
- > 3250L BLOO Septic

FREE DELIVERY TO MOST AREAS STATEWIDE

ORION AUSTRALIA package deals are the best way to ensure that your home water needs are fully serviced.



'Rural & Bush' Package

INCLUDES

- > 1 x 22,000L Poly Rainwater Tank
- > 1 x 10,000L Steel Rainwater Tank (firefighting water storage)
- > 50 LPM Pump
- > 3250L BLOO Septic

FREE DELIVERY TO MOST AREAS STATEWIDE

POPULAR ACCESSORIES



Tas Fire Approved Connection Fitting

In line with current Tasmanian fire protection policies, ORION AUSTRALIA recommend the installation of a Tas Fire approved fitting to any tanks that may be used for firefighting water supply.

MODEL	DESCRIPTION
RTFFSZ	Storz Fitting and blanking cap
RTFFO	50mm brass gate valve, Storz fitting and blanking cap



Inlet Float Valve

High quality float valve for use in 'pressure fill' applications. Suitable for use in mains pressure or gravity feed applications.

MODEL	DESCRIPTION
VALVE-APEX-1	25mm float valve complete with 25mm male thread

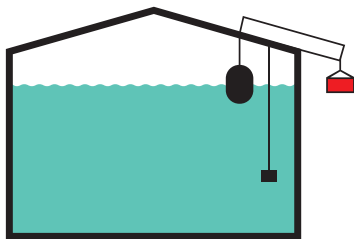

'True Level' Water Level Indicator

This popular 'true level' indicator keeps accurate track of the water level inside your tank and is designed to be easily visible from considerable distance away. Easy to install and can be retrofitted to most types of tank.

MODEL	DESCRIPTION
RTLY	True Level Indicator - Float Type



Actual pump may vary from unit pictured

Pressure Pump

ORION AUSTRALIA supplies a range of quality pressure pumps, designed to meet household needs, from small to very large houses.

- Stainless steel shaft
- Stainless steel pump housing
- Long life bearings
- 50-130psi per minute / 60 litre pump
- 3-9 tap capacities
- On/Off main motor switch
- Self priming up to 8 metres
- Run dry protection



Tank Water Level Controllers

Maintain the water level in your tank with the RainAid or Pump Buddy float valves. These valves are designed to ensure that there is always water in your tank, by giving preference to roof water but allowing mains or pump supply to assist if necessary.

MODEL	DESCRIPTION
RTRA	Rain Aid tank water level monitor
RTPB25	Pump Buddy tank water level monitor



Rain Tank Inlet Strainer

Minimise the entry of foreign debris and unwanted wildlife into your tank. High quality plastic strainer with integral insect mesh.

MODEL	DESCRIPTION
RTS200	Inlet strainer to suit 200mm diameter hole
RTS300	Inlet strainer to suit 300mm diameter hole
RTS400	Inlet strainer to suit 400mm diameter hole
RTS500	Inlet strainer to suit 500mm diameter hole



Tank Delivery

Larger ORION tanks are delivered free, direct to site, to most areas in Tasmania. Delivery vehicles may be up to 19m (62') in length, 3.0m (10') in width and 5m (17') in height. Please ensure that all delivery locations have access points that are of adequate width, have adequate turning space and are free of overhead obstructions.

In addition to our delivery staff, please ensure that there are a minimum of two physically fit persons on site to assist with deliveries of tanks over 10,000L capacity.

Tank Planner

SIDE VIEW

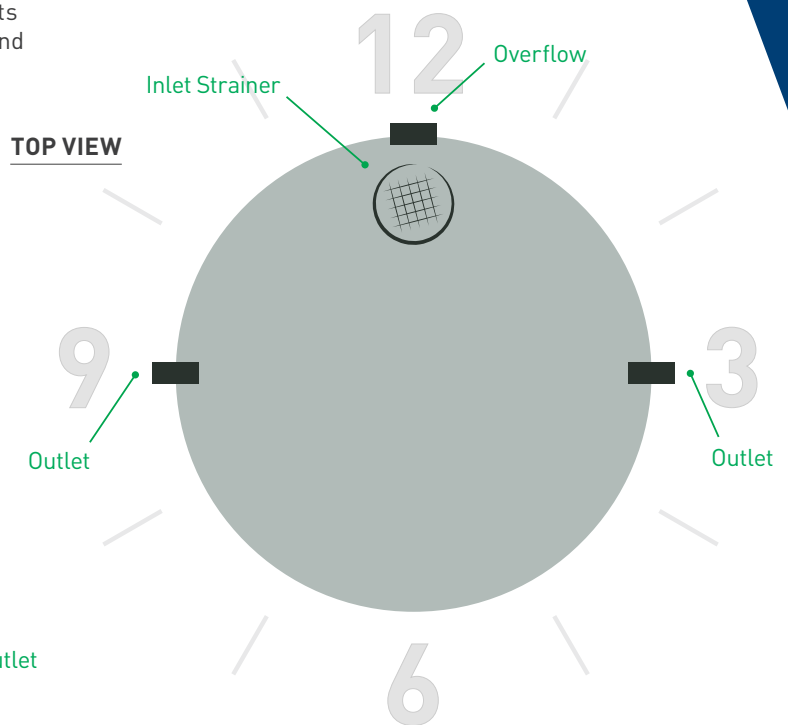
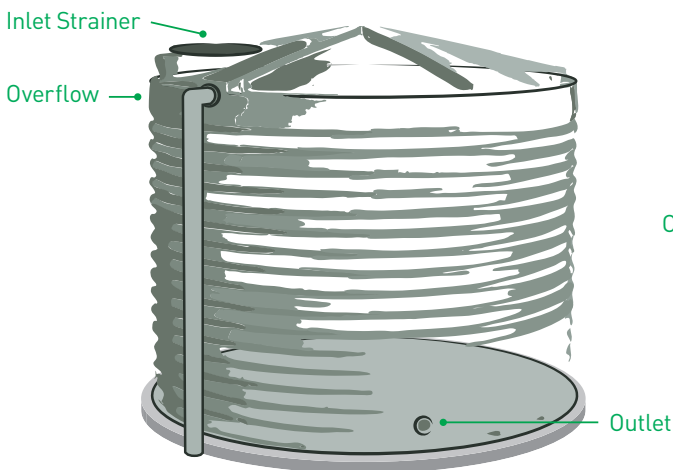

Installation on the ground

ORION AUSTRALIA Pty Ltd recommends that when installing tanks directly on the ground, that a concrete base is used.

- Ensure that the tank base is level, so as not to cause any undue stresses on the tank.
- Should a base of gravel, sand or other material be used, the purchaser must ensure the base material is contained in such a way that it cannot be washed away or otherwise removed from beneath the tank. A minimum depth of 75mm of compacted base material is needed between the base of the tank and the soil beneath.
- The tank base must be a minimum of 100mm larger in diameter than the tank/s placed upon it.
- It is the responsibility of the purchaser to ensure that the base is adequate, and Orion Australia Pty Ltd accepts no responsibility for failure due to inadequate construction of a proper tank base.

Installation on a tank stand

- If the tank is to be installed on a stand, it is the responsibility of the purchaser to ensure that any constructions meet local government regulations.
- It is the responsibility of the purchaser to ensure that design and construction of the stand are adequate for the total weight involved (remember that water weighs 1 kilogram per litre).
- Maximum gap between decking slats should be 20mm, and adequate support must be provided at intermediate points along the lengths of the slats.
- If using a wall mounted stand, ensure the wall and fastenings are adequate for the weight involved.
- The tank stand must be no smaller in diameter than the tank/s placed upon it.

FOR A FULL INSTALLATION GUIDE VISIT OUR WEBSITE, OR PHONE 1800 752 784

AVAILABLE FROM:



“I have been really happy with your prompt service, fantastic, thank you very much indeed!”

Susan,
Smithton, Tasmania

“Everything was delivered on time, as discussed. Thank you.”

Shane,
Sandford, Tasmania

“Great service, price and delivery”

Mark,
Westbury, Tasmania



ORION
AUSTRALIA

DIFFERENT. BETTER. GUARANTEED.

FRECALL
1800 752 784

WWW.ORIONAUSTRALIA.COM.AU